



# Wireless Voltage Sensor User Guide

VERSION 1.1  
SEPTEMBER 2019

---

---

## TABLE OF CONTENTS

1. QUICK START .....	2
2. OVERVIEW .....	2
2.1. Sensor Overview .....	2
2.2. Revision History .....	3
2.3. Document Conventions .....	3
2.4. Part Numbers .....	3
3. TECHNICAL SPECIFICATIONS .....	3
3.1. Absolute Maximum Ratings .....	3
4. BATTERY LIFE.....	4
5. TEST MESSAGES .....	5
6. MESSAGE PROTOCOL .....	5
6.1. Common Messages.....	5
6.2. Uplink Messages .....	6
6.3. Downlink Messages.....	7
6.3.1. Threshold Mode.....	7
6.3.2. Report on Change Mode.....	8
6.3.3. Periodic Reports.....	9
7. MECHANICAL DRAWINGS .....	10
7.1. INDOOR RBSX01 SENSORS.....	10
7.2. ARMORED OUTDOOR/INDUSTRIAL RBSX06 SENSORS .....	11
8. REGULATORY AND COMPLIANCE.....	12
8.1. Federal Communications Commission (FCC) .....	12
8.2. Harmonized Commodity Description (HS Code) .....	12
8.3. Export Control Classification Number (ECCN).....	12
9. CUSTOMER SUPPORT .....	13
10. DISCLAIMERS.....	13
11. LEGAL NOTICES .....	13
12. TRADEMARKS AND COPYRIGHT .....	13

## 1. QUICK START

To start using your sensor, simply go to:

<https://console.radiobridge.com>

From here you can register your device and immediately start receiving messages from the sensor.

The sensor configuration, message monitoring, and setting up alerts is usually self-explanatory through the user interface. For further explanations of any sensor features, you may refer to this [user guide](#)

## 2. OVERVIEW

### 2.1. Sensor Overview

The wireless sensors designed and manufactured by Radio Bridge provide full sensor to cloud solutions for Internet of Things (IoT) applications. The voltage sensor uses a 10-bit ADC to measure an analog value between 0-30V and provides 10mV of resolution. If the measured value rises above or falls below the configured thresholds, an alert is sent over the wireless network.

Features include:

- Built-in radio that talks directly with LoRaWAN wireless networks
- Two types of tamper detection: enclosure tamper and wall mount tamper
  - Enclosure tamper detects if the packaging of the sensor itself is opened or broken. Available on the RBSx01, RBSx05, and RBSx06 sensors.
  - Wall mount tamper detects if the sensor has been removed from the wall or mounting point. Available on the RBSx01 and RBSx05 sensors.
- 200,000+ transmissions on a single battery and a 5-10 year battery life depending on usage. See Battery section for more detail.
- Fully integrated internal antenna
- Over the air sensor configuration in the field
- Automatic low battery reporting and supervisory messages



## 2.2. Revision History

Table 1 Revision History

Revision	Date	Description
1.0	June 2019	Initial release of the document
1.1	September 2019	Updated common sections

## 2.3. Document Conventions

Table 2 Document Conventions

Font / Icon	Meaning
	Important notes
	Warnings and cautions

## 2.4. Part Numbers

Table 3 Part Numbers

Part Number	Rating	Wireless	Region
RBS306-VM30-US	Outdoor/Industrial	LoRaWAN	North America
RBS306-VM30-EU	Outdoor/Industrial	LoRaWAN	Europe

# 3. TECHNICAL SPECIFICATIONS

## 3.1. Absolute Maximum Ratings

Table 4 Absolute Maximum Ratings

Parameter	Rating	Units
Operating ambient temperature	-40 to +70	°C
Storage ambient temperature	-40 to +100	°C

## 4. BATTERY LIFE

The sensor uses a lithium non-rechargeable battery and is capable of 200,000+ total messages depending on the wireless standard and usage. For an accurate estimate of battery life, please refer to the “Sensor Battery Estimator.xlsx” spreadsheet on the Radio Bridge website. This spreadsheet combines usage information such as average number of messages per day and estimates the battery life for a particular sensor.



Refer to the spreadsheet “Sensor Battery Estimator.xlsx” on the Radio Bridge website for specific battery life estimates.

The power required for a message transmission is much greater than the “sleep current” (the power consumed when the sensor is inactive) for high power radio technologies such as LoRaWAN. This means that the battery life for most sensors is primarily dependent on the number of transmissions per day.

Different battery types will deplete over time with different voltage profiles. For instance, a lithium battery will maintain a relatively high voltage for the life of the battery and then experience a rapid drop near the end, whereas an alkaline battery will experience a more gradual reduction in voltage over time. Radio Bridge sensors are shipped with lithium batteries, and these are recommended when the battery needs to be eventually replaced.

Temperature also plays a role in battery life. The battery life estimates in the online spreadsheet assume room temperature, but temperatures close to the maximum and minimum ratings will have a negative impact on battery life. For example, battery voltage tends to be lower in cold temperatures and the internal circuitry needs a certain minimum voltage to operate properly before it will shut down. Thus, battery life will tend to be shorter when running the sensor in cold environments.



Battery voltage will be lower in cold temperatures and thus battery life will be reduced in cold environments.

The battery voltage is reported by the supervisory messages as well as a low battery indicator. See the section on Message Protocol for more detail.

## 5. TEST MESSAGES

The sensor can be triggered to send test messages by placing a magnet next to the side of the sensor. The location of the magnet is indicated by the triangular notch on the side of RBSx01 and RBSx05 sensors. RBSx04 sensors do not have this capability. There is a small magnetic Hall effect sensor that will detect the presence of a magnet and send a message. This can be used for diagnostic purposes to ensure the sensor is within range and connected to the network.

## 6. MESSAGE PROTOCOL

This section defines the protocol and message definitions for the sensor.



---

Radio Bridge provides a web-based console at [console.radiobridge.com](http://console.radiobridge.com) to configure and monitor sensors. Usage of this console is highly recommended for most customers rather than implementing the protocols defined in this section.

---

If the standard Radio Bridge console ([console.radiobridge.com](http://console.radiobridge.com)) is not used, refer to this section to decode the sensor data and configure the sensor through downlink messages.

### 6.1. Common Messages

There are common messages across all wireless sensors that are defined in the document “Common Sensor Messages” which is available on the Radio Bridge website.



---

Refer to the document “Common Sensor Messages” for definitions of all common messages. Common messages are not defined in this document.

---

Common messages include basic error messages, tamper, supervisory, and downlink ack. It is important to refer to that document prior to decoding the messages defined in this section.

## 6.2. Uplink Messages

The uplink message (sensor to web application) specific to the sensor is defined in following table. The common uplink messages are not included in this section (see common messages document).

*Table 5 Uplink Message 0x14: Voltage Measurement Event*

Byte	Description
0	Voltage Measurement Event Payload (see Voltage Measurement Event Payload Definitions)
1-2	Voltage measurement in units of 10mV (range 0-3000)

The voltage measurement event is defined in the following table.

*Table 6 Voltage Measurement Event Payload Definitions*

Event Payload	Description
0x00	Periodic report
0x01	Analog measurement has risen above upper threshold
0x02	Analog measurement has fallen below lower threshold
0x03	Report on change increase
0x04	Report on change decrease

The voltage measurement field in the uplink message is the analog measurement in increments of 10mV with a range of 0-30V (0-3000).

## 6.3. Downlink Messages

The downlink message (web application to sensor) specific to the sensor configuration is defined in following table. The common downlink messages are not included in this section (see common messages document).

*Table 7 Downlink Configuration Message 0x14*

Byte	Description
0	Mode: 0x00 for Threshold, or 0x01 for Report on Change
1-6	Defined by Mode (See Mode sections)

The mode byte selects one of two modes: threshold-based alerts or report-on-change alerts. The remainder of the payload (bytes 1-6) are determined by the mode selected and defined in the next two sections.

### 6.3.1. Threshold Mode

Threshold mode is set when byte 0 of the payload is set to 0x00. The remainder of the payload is defined in the following table.

*Table 8 Downlink Configuration Message for Threshold Mode*

Byte	Description
0	0x00 (Threshold mode)
1	Periodic reporting in 1 minute or 1 hour intervals. Default is 0 (disabled)
2	Restoral margin. Default is 100mV.
3-4	Lower analog measurement threshold. Default 10V.
5-6	Upper analog measurement threshold. Default 12V.

The upper and lower thresholds are *unsigned* values with units of 10mV. Note that if the configuration settings exceed the maximum ratings on the sensor, the sensor may not report an event.



The Restoral Margin is used for the upper and lower thresholds and requires the measurement value to cross back over the threshold a certain amount before a new event is reported. This prevents excessive event messages if the measurement is at or near the threshold.

For example, consider an upper threshold set at 15V and the restoral margin set at 1V. If the measurement initially exceeds 15V then an event is generated and a message is sent to the network. The measurement must now drop to 14V and then exceed 15V before another event is reported.

The restoral margins are *unsigned* values with units of 10mV (range is 2.55V). If a restoral margin is set to 0, it is disabled.

Periodic reporting is described in the section Periodic Reports.

### 6.3.2. Report on Change Mode

Report on Change mode is set when byte 0 of the payload is set to 0x01. The remainder of the payload is defined in the following table.

*Table 9 Downlink Configuration Message for Report on Change Mode*

Byte	Description
0	0x01 (Report on Change mode)
1	Periodic reporting in 1 minute or 1 hour intervals. Default is 0 (disabled)
2	Not used
3-4	Analog measurement increase
5-6	Analog measurement decrease

If the increase or decrease values are non-zero, then the sensor will send an alert any time the analog measurement changes by the specified amount. For example, if the measurement increase and decrease are set to 5V, then an alert is sent every time the measurement changes 5V from the last report. The increase and decrease are unsigned values with units of 10mV.

Periodic reporting is described in the section Periodic Reports.

### 6.3.3. Periodic Reports

The voltage measurement sensor can also send periodic updates, and this is defined in byte 1 of both modes. A setting of 0 will disable periodic reporting. The period is defined in 1 hour increments when the most significant bit is 0, and it is defined in 1 minute increments when the most significant bit is 1 as shown in the following table.

*Table 10 Period Bye (byte 1) from Downlink Configuration Message*

Bit 7	Bits 6:0
0	Period defined in hours (1-127 hours)
1	Period defined in minutes (1-127 minutes)

For example, to receive a report every 4 hours, byte 1 would be set to 0x04. To receive a periodic report every 15 minutes, byte 1 would be set to 0x8f.



Periodic reporting is not recommended as it will increase data service fees and significantly reduce battery life. Wherever possible, use thresholds or report-on-change only.

## 7. MECHANICAL DRAWINGS

The mechanical drawings provided in this section are for the main body of the sensor. All dimensions are inches unless otherwise noted.

### 7.1. INDOOR RBSx01 SENSORS

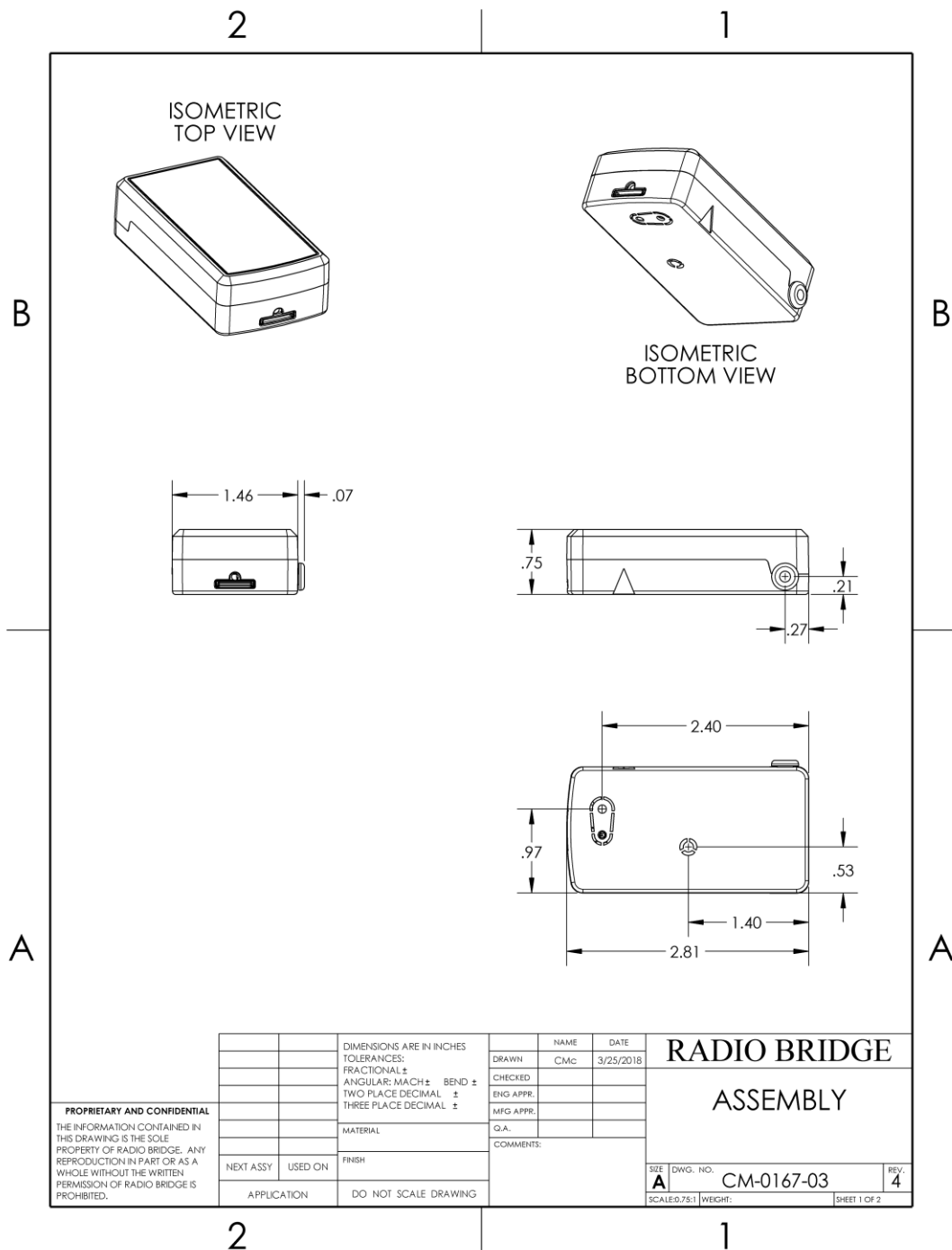

## 7.2. ARMORED OUTDOOR/INDUSTRIAL RBSX06 SENSORS

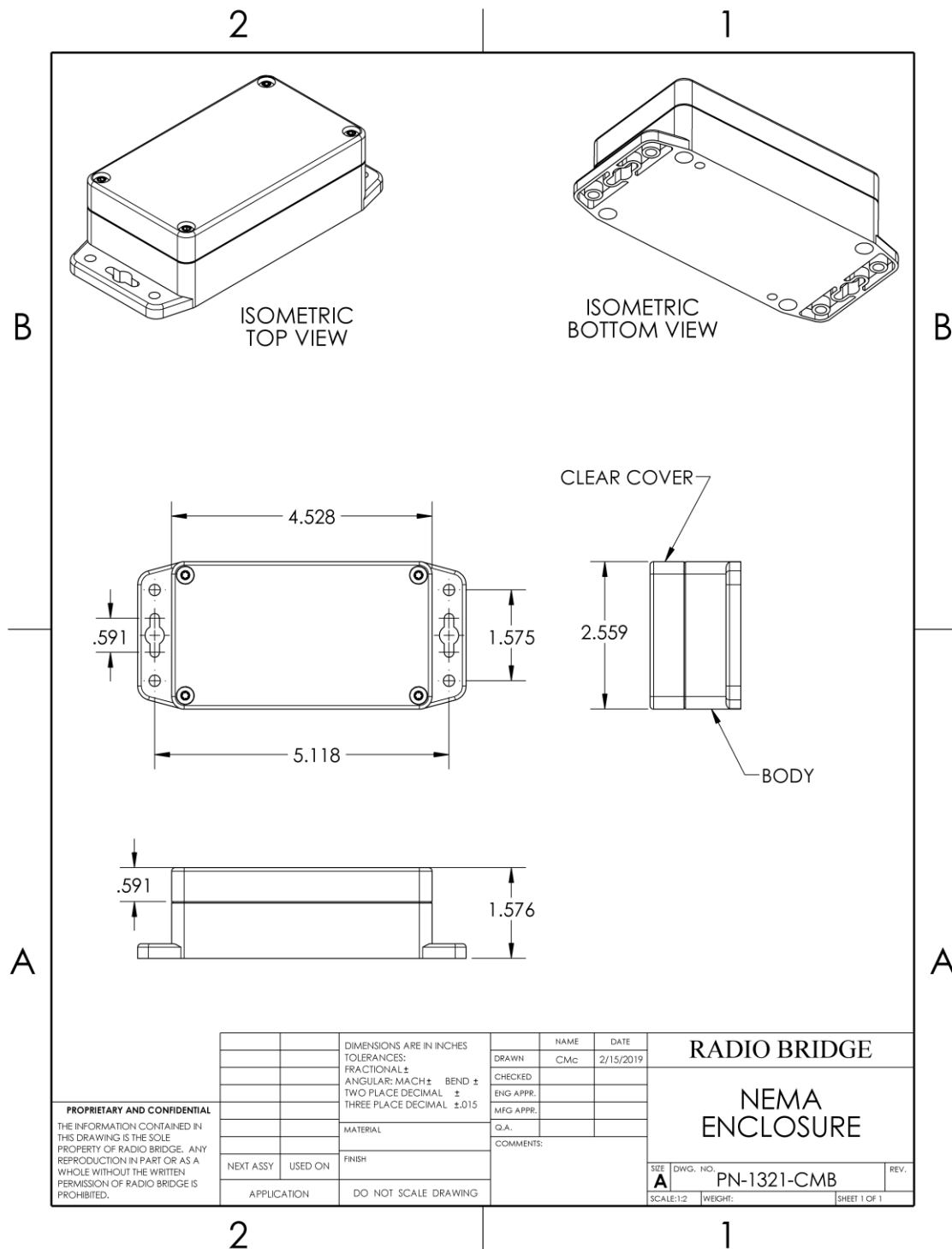

## 8. REGULATORY AND COMPLIANCE

### 8.1. Federal Communications Commission (FCC)

Per FCC 15.19(a)(3) and (a)(4) This device complies with part 15 of the FCC Rules. Operation is subject to the following two conditions: (1) This device may not cause harmful interference, and (2) this device must accept any interference received, including interference that may cause undesired operation.

Per FCC 15.21, Changes or modifications not expressly approved by Radio Bridge could void authority to operate the devices.

Sigfox RBS101, RBS104, and RBS105 sensors FCC ID: 2APNUSFM10R2

LoRaWAN RBS301, RBS304, and RBS305 sensors FCC ID: 2APNUCMABZ

LoRaWAN RBS306 sensors: This device contains FCC IAU792U13A16858

This device contains equipment certified under IC: 125A-0055

### 8.2. Harmonized Commodity Description (HS Code)

The Harmonized Commodity Description and Coding System generally referred to as “Harmonized System” or simply “HS” is a multipurpose international product nomenclature developed by the World Customs Organization (WCO).

HS Code: 8531.90

### 8.3. Export Control Classification Number (ECCN)

ECCNs are five character alpha-numeric designations used on the Commerce Control List (CCL) to identify dual-use items for export control purposes. An ECCN categorizes items based on the nature of the product, i.e. type of commodity, software, or technology and its respective technical parameters.

ECCN: 5a992.c

## 9. CUSTOMER SUPPORT

Radio Bridge offers free technical support at:

<https://support.radiobridge.com>

Radio Bridge also offers technical support plans and service packages to help our customers get the most out of their Radio Bridge products.

## 10. DISCLAIMERS

Information in this document is subject to change without notice and does not represent a commitment on the part of Radio Bridge. Radio Bridge provides this document “as is,” without warranty of any kind, expressed or implied, including, but not limited to, the implied warranties of fitness or merchantability for a particular purpose. Radio Bridge may make improvements and/or changes in this manual or in the product(s) and/or the software described in this manual at any time.

## 11. LEGAL NOTICES

See the [Legal Notices](#) section of the website for up to date information on Radio Bridge’s warranty, returns policy, privacy statement, terms of sale, and terms of service.

## 12. TRADEMARKS AND COPYRIGHT

Radio Bridge™, SubGig®, Armored Sensor™ and BridgeBee® are trademarks of Radio Bridge Inc in the United States.

© 2019 Radio Bridge Inc. All rights reserved